

installation & maintenance

CONDENSING UNITS

CUS 15 - 60 / HCU 20 - 30D



FM00542

EMS52086

About Airedale

WARRANTY, COMMISSIONING & MAINTENANCE

Our standard warranty package guarantees all parts for 24 months. Additional customised warranty packages are also available for periods of 12 to 36 months covering either parts only or parts and labour.

Having chosen your Airedale product, a full commissioning service is now available on all products and is charged on a daily rate variable by location.

To further protect your investment in Airedale products, we have also introduced our own Planned Maintenance Service. This includes nation-wide service cover 24 hours a day, 365 days a year, plus regular planned maintenance visits. For a free quotation contact our Field Service Department or your Local Sales Engineer.

TRAINING

As well as our comprehensive range of products, Airedale offers a modular range of Refrigeration and Air Conditioning Training courses, for further information please contact our Training Co-ordinator.

CUSTOMER SERVICES

For further assistance, please e-mail: enquiries@airedale.com or telephone:

UK Sales Enquiries	+ 44 (0) 113 238 7789	uk.sales@airedale.com
International Enquiries	+ 44 (0) 113 239 1000	enquiries@airedale.com
Spares Hot Line	+ 44 (0) 113 238 7878	spares@airedale.com
Airedale Service	+ 44 (0) 113 239 1000	service@airedale.com
Technical Support	+ 44 (0) 113 239 1000	tech.support@airedale.com
Training Enquiries	+ 44 (0) 113 239 1000	marketing@airedale.com

For information, visit us at our Web Site: www.airedale.com

AIAC Ltd endeavours to ensure that the information in this document is correct and fairly stated, but none of the statements are to be relied upon as a statement or representation of fact. AIAC Ltd does not accept liability for any error or omission, or for any reliance placed on the information contained in this document.

The development of Airedale products and services is continuous and the information in this document may not be up to date. It is important to check the current position with AIAC Ltd at the address stated. This document is not part of a contract or licence unless expressly agreed.

No part of this document may be reproduced or transmitted in any form or by any means, electronic or mechanical, including photocopying, recording, or information storage and retrieval systems, for any purpose other than the purchaser's personal use, without the express written permission of AIAC Ltd.

© 2014 Airedale International Air Conditioning Limited. All rights reserved.
Printed in the UK.

Description	Page 4
General	
Safety	Page 5
Spares	Page 5
Serial Plate	Page 5
Warranty	
Main Terms	Page 6
Procedures	Page 6
Returns Analysis	Page 7
Loose Items List	Page 7
Component Location / Description	Page 8
Site Installation Guide	
Lifting / Positioning / Levelling	Page 9
Mechanical Information	
Technical Data Sheet	Page 10
Dimensions	Page 11
Refrigeration System	
Refrigeration Pipework Schematics	Page 14
System Holding Charge	Page 15
Pipework Sizing / Oil Addition	Page 15
Pressure Testing	Page 15
Evacuation	Page 15
Refrigerants	Page 15
Electrical Information	
Electrical information - Control panel components	Page 16
Electrical Data Sheet	Page 17
Terminal Blocks - External Connections	Page 18
Commissioning Procedures	
Commissioning Sheet - Example	Page 19
Pre-Start Checks	Page 20
Refrigeration Circuits - Charging	Page 20
Head Pressure Controller Adjustment	Page 20
Troubleshooting Tables	Page 22
Maintenance Requirements	
Periodic Maintenance Schedule	Page 25

Description

INTRODUCTION

The condensing units comprise a compact housing incorporating all the necessary components and associated controls required.

The multiple condenser fan and motor assemblies provide an even airflow across the condenser coils and then discharge vertically upwards. The condenser coils are in a “V” formation on units in the range CUS 15 to 30D and in a twin vertical formation on units in the range CUS 40 to 60D and HCU 20 to 30D.

COMPRESSORS

CUS 15 - 30D AND HCU 20 - 30D

Three phase hermetic scroll compressors are used in this range of condensing units. They are fitted with an internal thermal protector to protect the compressor from damage against high motor winding and discharge gas temperatures.

CUS 40 - 60D

Three phase fully hermetic twin scroll compressors are used enabling each of the two circuits to operate at 50% or 100% duty according to demand. Each twin compressor is fitted with a thermistor protector module to protect the compressor from an overheat condition.

REFRIGERATION

Each circuit is fitted with a liquid line shut-off valve to allow for isolation of the condensing unit during service or maintenance, and this is fitted with a schraeder access connector to facilitate connection of a service gauge manifold.

The suction line connection is capped and sealed ready for customer connection.

A large capacity filter drier is supplied loose for on-site installation.

A manual high pressure and automatic low pressure cut-out switch is fitted on each circuit for system safety.

All units are configured to operate without pump-down.

CONTROL PANEL

The control panel is equipped with the necessary MCB's, contactors and other items to provide fully automatic safe operation. It is divided into mains and control sections thereby ensuring voltage integrity between mains (400/230V) and controls (24V).

OPTIONS

1. When specified, the condenser fan is electronically speed controlled to ensure that a stable head pressure can be achieved during all seasons.
2. A weatherproof mains isolator can be fitted to ensure mains isolation of the electrical panel during adjustment and maintenance.
3. A soft start option may be fitted to compressors on the CUS 15 to 25D range. This consists of a resistor bank which is inserted in the compressor circuit for 0.3 of a second to reduce current inrush.
4. In atmospheres where high corrosion is anticipated phenolic coated aluminium finned coils can be supplied.
5. A large open mesh coil protection guard can be supplied for sites where coil damage might be a problem (HCU20-30D only).
6. Compressors can be supplied charged with Ester oil suitable for use with the environmentally friendly refrigerant R407C.

General Statement

IMPORTANT

The information contained in this manual is critical to the correct operation and maintenance of the unit and should be read by all persons responsible for the installation, commissioning and maintenance of this Airedale equipment.

SAFETY

The equipment has been designed and manufactured to meet international safety standards but, like any mechanical/electrical equipment, care must be taken if you are to obtain the best results.

- 1 Service and maintenance of Airedale equipment should only be carried out by skilled personnel.
- 2 When working with any air conditioning units ensure that the electrical isolator is switched off prior to servicing or repair work and that there is no power to any part of the equipment.
- 3 Also ensure that there are no other power feeds to the unit such as fire alarm circuits, BMS circuits, etc.
- 4 Electrical installation, commissioning and maintenance work on this equipment should be undertaken by competent and trained personnel in accordance with local relevant standards and codes of practice.
- 5 Refrigerant No 22 and 407C used in this range of products is classified under the COSHH regulations as an irritant, with set Occupational Exposure Levels (OEL) for consideration if this plant is installed in confined or poorly ventilated areas.
- 6 A full hazard data sheet in accordance with COSHH regulations is available should this be required.

SPARES

A recommended spares list is included in the unit documentation pouch located inside the unit. For ease of identification when ordering spares or contacting Airedale about your Condensing unit, please quote the unit type, unit serial number and the date of manufacture. This information can be found on the serial plate attached to the unit. An area has been provided on the front cover of this manual for this information to be recorded.

SERIAL PLATE EXAMPLE

AIREDALE		UK OFFICE Tel: 00 44 113 239 1000 Fax: 00 44 113 250 7219
Airedale International Air Conditioning Ltd.		
UNIT/GERÄT/UNITE		CUS10HI
SERIAL/SERIE/SERIE		U60179
MANUFACTURED/HERGESTELLT/FABRIQUE		4/11/98
SUPPLY/SPANNUNG/ALIMENTATION		400V 3PH 50Hz
FUSE/HAUPTSICHERUNG/FUSIBLES		40.0 A
REFRIGERANT & CHARGE		
KÄLTEMITTEL & LADUNG		R407C
REFRIGERANT & CHARGE		
TEST PRESSURE		
DRUCKPRÜFUNG		20.0 BAR
PRESSION D'ESSAI		
DEUTSCHES BÜRO TEL : 00 49 6108 90040 FAX : 00 49 6108 77972		BUREAU FRANCAIS TEL : 00 331 34 653344 FAX : 00 331 334 653088
		 

Warranty

IMPORTANT

For the warranty to be valid, copies of the relevant commissioning sheets must be fully completed and returned to Airedale, Leeds, within 28 days of commissioning the equipment. Failure to submit the commissioning sheets within the specified time period will invalidate any future warranty claims.

MAIN TERMS

The following warranty conditions are subject to the Airedale equipment being regularly serviced and maintained in accordance with the installation and maintenance documents by a competent and qualified installation and maintenance company, approved by Airedale during the warranty period.

Airedale will respect warranty cover on all component parts for a period of 24 months commencing from despatch of equipment from the Airedale factory. Extended warranty to afford 24 months cover from commissioning of plant can be supplied upon written request.

Airedale warranty cover is appropriate to component parts only and does not include any allowance for labour costs or other expenses involved in the replacement of faulty parts, within the warranty period.

Replaced faulty parts should be returned to Airedale within 21 days for full evaluation.

Parts fitted under warranty shall be warranted for the unexpired period of warranty of the equipment or 3 months from delivery whichever period is the longer. This excludes compressors on which a further 12 months warranty is granted.

PROCEDURE

When a component part fails, a replacement part should be obtained through our Spares department. If the part is considered to be under warranty, the following details are required to process this requirement.

- Full description of part required, including Airedale's part number, if known.
- The original equipment serial (U) number.
- An appropriate purchase order number.

A spares order will be raised under our "G" number system and the replacement part will be despatched, usually within 24 hours.

When replaced, the faulty part must be returned to Airedale with a suitably completed and securely attached "Faulty Component Return" (FCR) tag, supplied with each component. FCR tags are available from Airedale Spares Department and supplied with each "G" order.

On receipt of the faulty part, suitably tagged, Airedale will pass it to its Warranty department, where it will be fully inspected and tested in order to identify the reason for failure, identifying at the same time whether warranty is justified or not.

On completion of the investigation of the returned part, a fully "Report on Goods Returned" will be issued. On occasion the release of this complete report may be delayed as component manufacturer becomes involved in the investigation.

Warranty PROCEDURE

When warranty is allowed, a credit against the "G" number invoice will be raised. Should warranty be refused the "G" number invoice becomes payable on normal terms.

Warranty may be refused for the following reasons:

- Misapplication of product or components.
- Replaced part being returned damaged without explanation.
- Unnecessary delays incurred in return of defective component.

RETURNS ANALYSIS

All faulty components returned under warranty are analysed on a monthly basis as a means of verifying component and product reliability as well as supplier performance. It is important that all component failures are reported correctly.

Loose Items List

FILTER DRIER

A suitably sized liquid line filter drier is shipped loose in the refrigeration compartment of the condensing unit. This has been chosen to match the required refrigeration duty of the compressor. To access this item, remove the service cover at the electrical panel end by undoing the catches and lifting off.

Component Location

COMPRESSORS

HCU 20 - 30D

The compressors are located in the centre of the unit and are accessed by key operated lockable covers.

CUS 15 - 30D

The compressors are housed in the enclosed compartment which is at one end of the condensing unit and accessible by a series of key operated lockable covers.

CUS 40 - 60D

The compressors are housed between the condenser coils and are accessible via lockable access covers located at the opposite end of the unit from the control panel.

CONTROL PANEL

HCU 20 - 30D

This is mounted at one end of the unit. It contains all the necessary breakers, contactors and terminals required to operate the unit.

CUS 15 - 30D

This is mounted above the compressor in the same compartment. It carries all the necessary breakers, contactors and terminals required to operate the unit

CUS 40 - 60D

This is mounted in the enclosed end of the unit. It carries all the necessary breakers, contactors and terminals required to operate the unit.

CONDENSER FAN AND MOTOR UNITS

These are integral fan / motor units and are mounted so as to give a vertical discharge of air from the condensing units.

COMPRESSOR ANTI-CYCLE TIMERS (STANDARD FITMENT)

These are fitted on the control panel and wired in to the control system. It is normally recommended that this be set to a ten minute interval.

HEAD PRESSURE CONTROLLER (WHEN FITTED)

CUS 15 - 30D AND HCU 20 – 30D

This fan speed controller is a single controller with the two sensors connected to it. It operates to sense both circuits at the same time and will sense whichever circuit has a head pressure that is requiring controlling and will vary the fan speeds accordingly.

CUS 40 - 60D

A separate fan speed controller is fitted to each circuit and will vary the fan speeds for each circuit accordingly.

Site Installation Guide

LIFTING

Whenever a condensing unit is lifted, lifting should be from the base. Where possible, all packing and protection should be left in position. If any type of slinging is used, due care should be taken to ensure that the slings do not crush the casework or coil.

Spreader bars shall be used to ensure that any slings or chains used in the lifting process do not crush the framework of the unit or damage the coil faces.

Due note shall also be made of the fact that the compressor is at one end of the unit, and therefore the centre of gravity will also be towards that end.

If the unit is dropped, it shall immediately be checked for damage.

POSITIONING AND LEVELLING

The condensing unit shall be positioned on a stable load bearing and even base. This base shall be levelled to ensure that the compressor operates correctly without uneven internal stresses being transmitted to the compressor support.

Mechanical Information

CUS 15 - 60D

CUS		15D	20D	25D	30D	40D	50D	60D
Nominal Capacity	kW	41.8	50.2	71.1	80.7	104.0	131.4	161.4
Nominal Airflow	m ³ /sec	4.00	4.80	6.80	6.80	9.60	13.60	13.00
Max. Fan Speed	rpm	930	930	930	930	930	930	930
Refrigerant		R407C	R407C	R407C	R407C	R407C	R407C	R407C
Refrigerant Charge/Circ	kg	6.5	9.0	9.0	9.0	10.5	10.5	11.8
Oil Charge	l	4.0	4.0	4.0	6.6	9.9	9.9	9.9
Liquid Line Connection	ins	5/8	5/8	5/8	5/8	1 1/8	1 1/8	1 1/8
Suction Line Connection	ins	1 1/8	1 1/8	1 1/8	1 3/8	1 5/8	2 1/8	2 1/8
Machine Weight	Kg	440	540	550	695	978	1119	1356

Notes:

- 1 Based on 5°C evaporating and a 30°C ambient.
- 2 Refrigeration charge is for information purposes only. The units do not leave the factory charged.
- 3 All terminations are suitable for sweat connections.

HCU 20 - 30D

HCU		20D	25D	30D
Nominal Capacity	kW	58.6	69.5	81.0
Nominal Airflow	m ³ /sec	6.80	6.80	6.80
Max. Fan Speed	rpm	930	930	930
Refrigerant		R407C	R407C	R407C
Refrigerant Charge/Circ	kg	10.1	10.3	10.5
Oil Charge	l	4.0	4.0	6.6
Suction Line Connection	ins	1 1/8	1 1/8	1 3/8
Liquid Line Connection	ins	5/8	5/8	5/8

Notes:

- 1 Based on 5°C evaporating and a 35°C ambient
- 2 Refrigeration charge is for information purposes only. The units do not leave the factory charged.
- 3 All terminations are suitable for sweat connections.

Dimensions: CUS 15D - 30D

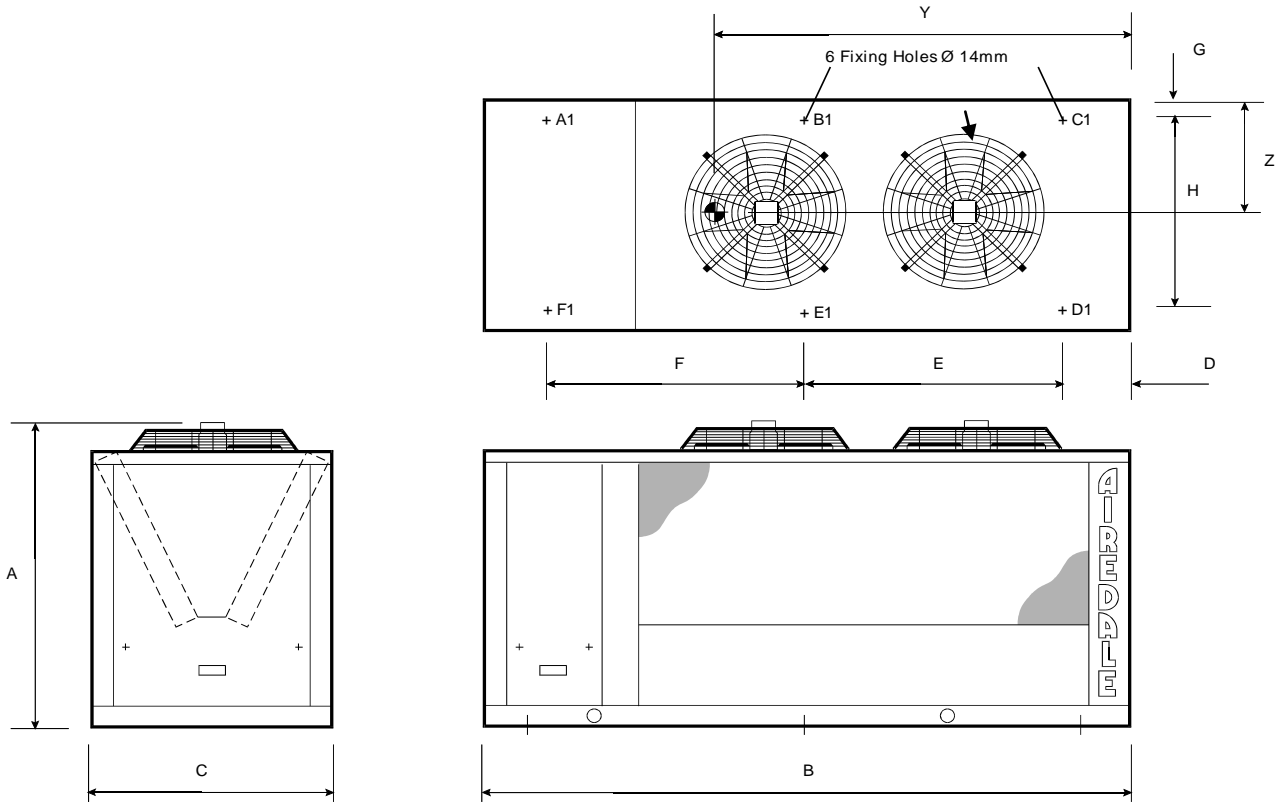

		A	B	C	D	E	F	G	H
CUS 15D	mm	1438	2300	1100	200	-	-	25	1050
CUS 20D	mm	1438	2900	1100	200	1250	1250	25	1050
CUS 25D	mm	1438	2900	1100	200	1250	1250	25	1050
CUS 30D	mm	1438	3000	1100	200	1300	1300	25	1050

	Point Loadings (kg)						Centre of Gravity (mm)	
	A1	B1	C1	D1	E1	F1	Y	Z
CUS 15D	146	-	101	101	-	156	1330	560
CUS 20D	130	120	56	56	121	140	1770	560
CUS 25D	130	122	57	57	123	141	1765	560
CUS 30D	174	140	78	77	138	179	1785	550

Notes:

- 1 Suction and liquid connections terminate underneath the condenser coil.
- 2 Allow 500mm around the unit for airflow and maintenance clearance.

Dimensions: CUS 40D - 60D

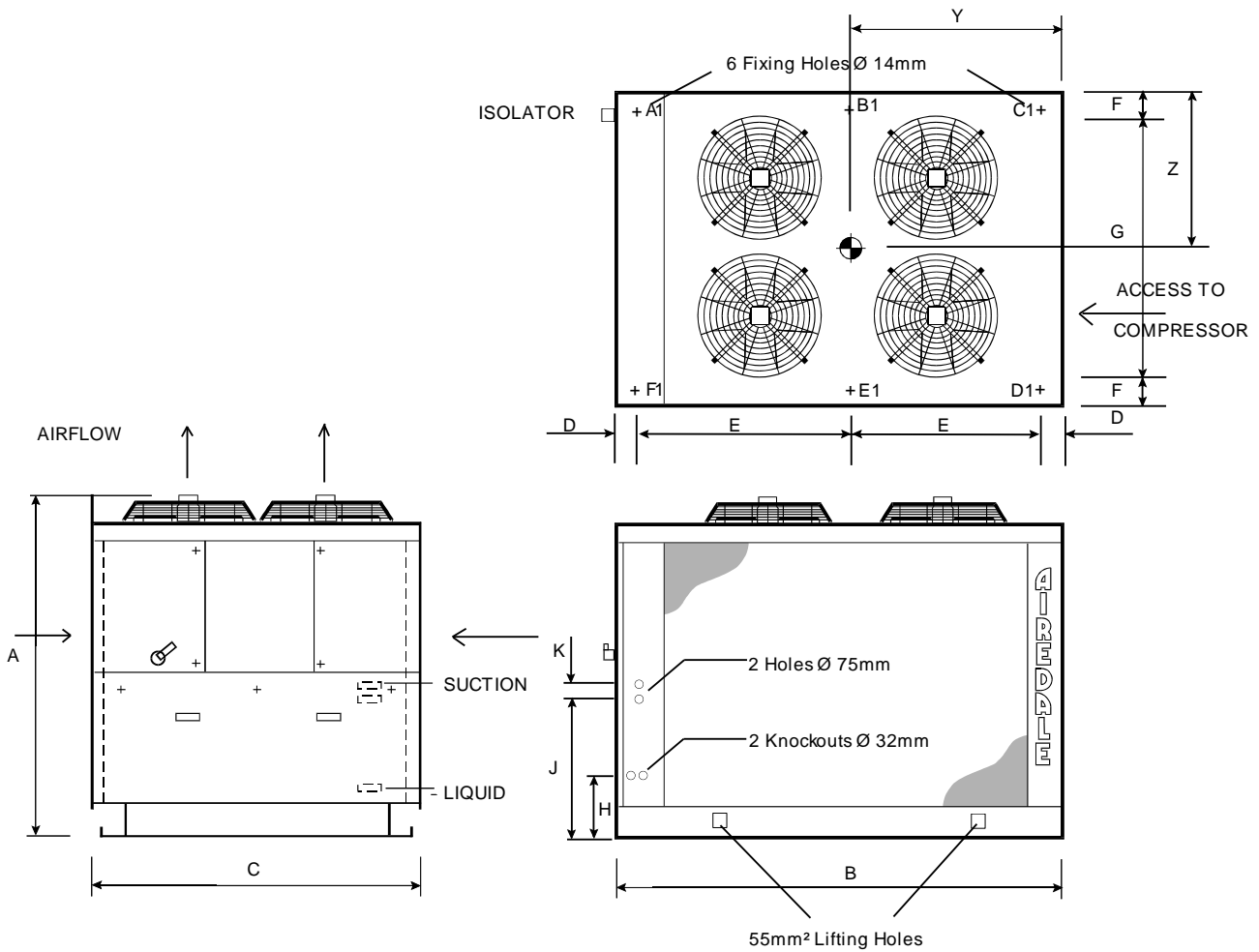

		A	B	C	D	E	F	G	H	J	K
CUS 40D	mm	1693	2440	1800	200	1020	75	1650	155	595	100
CUS 50D	mm	1693	2440	1800	200	1020	75	1650	155	595	100
CUS 60D	mm	1693	2440	1800	200	1020	75	1650	155	595	100

	Point Loadings (kg)						Centre of Gravity (mm)	
	A1	B1	C1	D1	E1	F1	Y	Z
CUS 40D	148	174	174	174	174	149	1169	896
CUS 50D	157	206	206	208	206	156	1136	900
CUS 60D	180	254	254	258	255	180	1116	900

Note: Allow 500mm around the unit for airflow and maintenance clearance.

Dimensions: HCU 20 - 30D

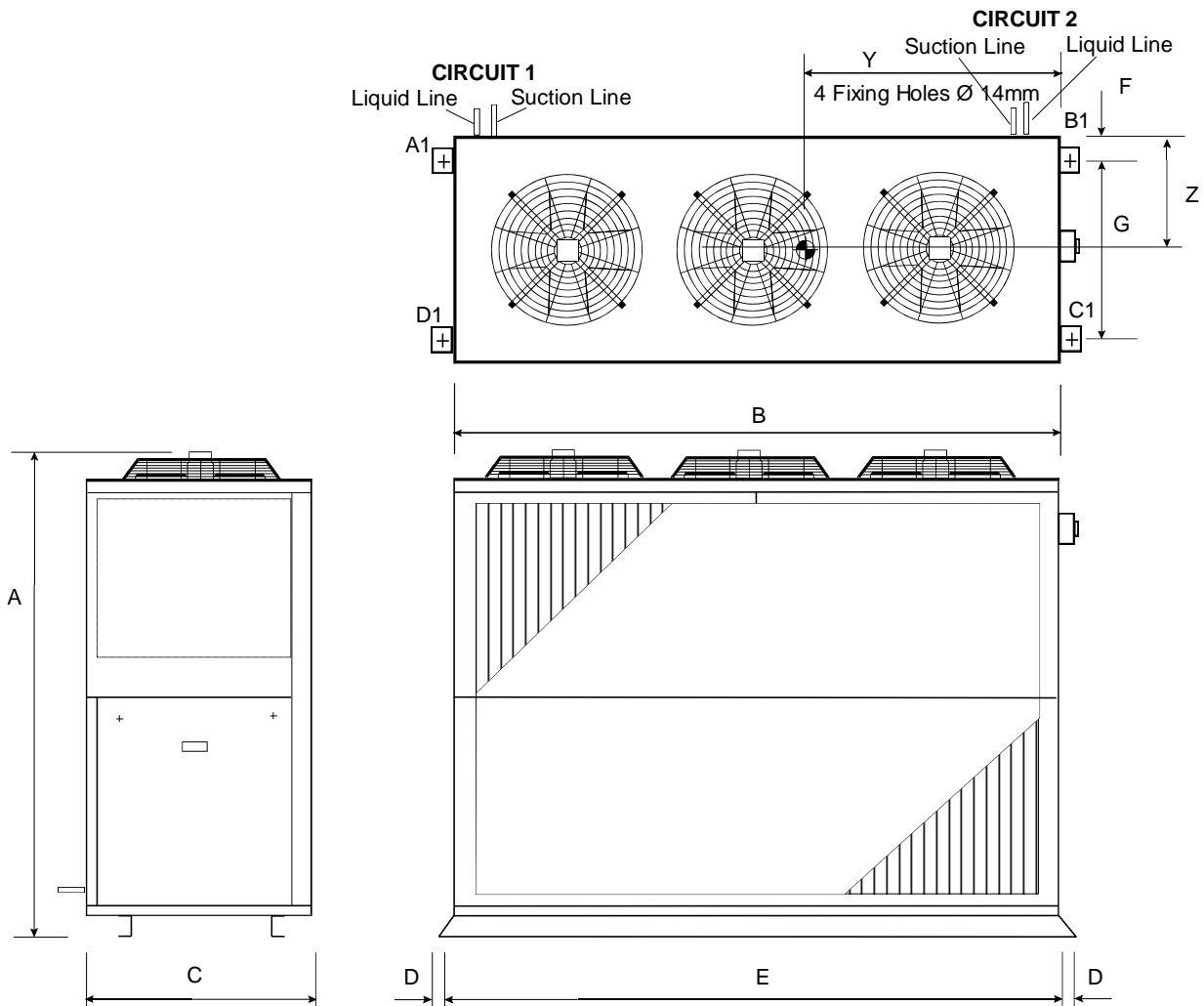

HCU		A	B	C	D	E	F	G
20D	mm	1993	2280	805	30	2370	150	505
25D	mm	1993	2280	805	30	2370	150	505
30D	mm	1993	2280	805	30	2370	150	505

HCU	Point Loadings (kg)				Centre of Gravity (mm)		
	A1	B1	C1	D1	Y	Z	
20D	140	157	139	131	1088	391	
25D	140	157	139	131	1088	390	
30D	186.2	206.7	155.7	151.4	1098	372	

- 1 Suction and liquid connections terminate on the opposite side of the unit to the condenser coil face.
- 2 Allow 1000mm clearance on the coil side for airflow and 500mm clearance on the 3 other sides for maintenance

Refrigeration System

REFRIGERATION PIPEWORK SCHEMATICS

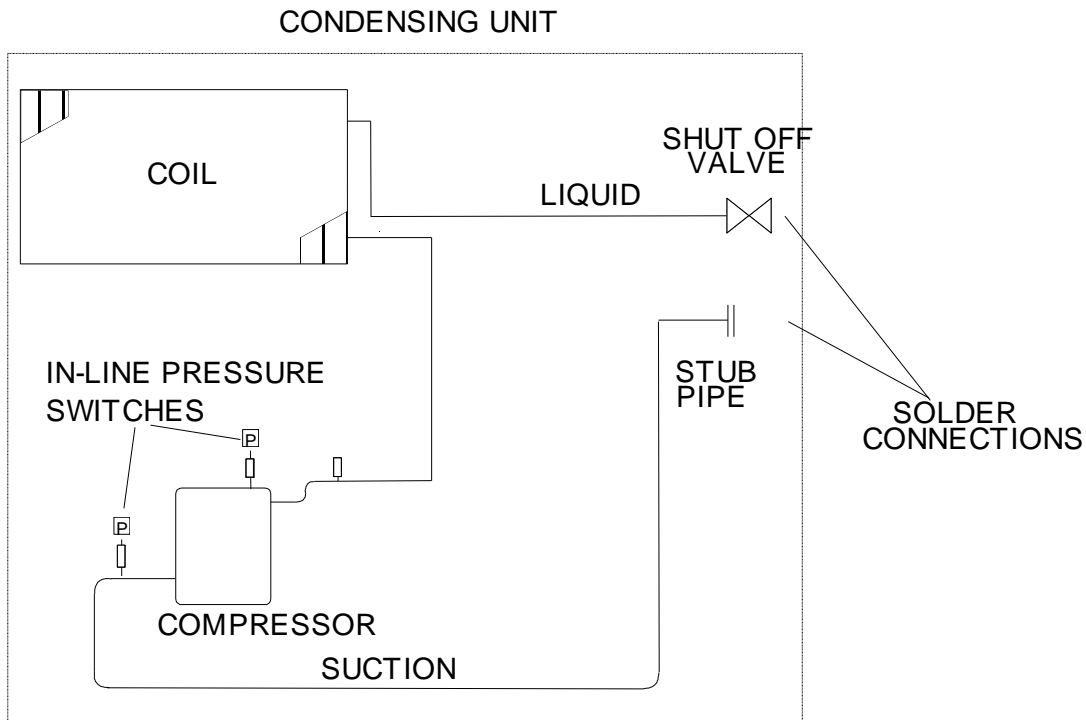

Notes:

- 1 Compressor connections are diagrammatic only - not actual.
- 2 For clarity only one circuit is shown although all units are twin circuit.

Refrigeration System

HOLDING CHARGE

All units are shipped with a holding charge of dry nitrogen. This is to ensure that there is no risk of internal contamination or moisture entering the units during shipping or storage.

Before the units are evacuated prior to the charging process, the condensing unit should be checked to see that the holding charge has been retained. If it appears to be either partially or totally lost, then the unit concerned should be carefully checked for signs of physical damage.

PIPEWORK SIZING/OIL ADDITION.

It is **MOST IMPORTANT** that the correct size refrigeration pipework is used to ensure that the pressure drop in the system is kept to a minimum, and also so that proper oil return will take place under all normal operating conditions.

Accepted Good Practice should be followed in the design and installation of the refrigeration pipework system.

Oil should be added to the pipework installation in accordance with the compressor manufacturers recommendations where applicable.

PRESSURE TESTING

When installation is complete, fill the system with dry nitrogen to a pressure of 17 bar/250 psig. Record the pressure over a period of time (a minimum period of 60 minutes should be sufficient to detect any major leaks, however, ideally 24 hours should be allowed). If there is any reduction in pressure, trace the leak and repair before conducting a further pressure test.

EVACUATION

Evacuation should be carried out with a high vacuum pump. The pump should be connected to the high and low pressure sides of the system via a gauge manifold fitted with compound gauges. A high vacuum gauge should be fitted to the system at the furthest point from the vacuum pump.

Triple evacuation should be used to ensure that all contaminants are removed or at least reduced to significantly low proportions.

There are no hard and fast rules when applying this method. However, the following has proved effective for general installation and service work.

1. Recover system charge and pressure test.
2. Replace filter drier.
3. Evacuate to (10 Torr) 13 mBar and maintain for 20 minutes.
4. Break vacuum with OXYGEN FREE dry nitrogen to 0.5 Bar (7psi) and hold for 15 minutes.
5. Evacuate to (5 Torr) 7mBar and maintain for 20 minutes.
6. Break vacuum with OXYGEN FREE dry nitrogen to 0.5 Bar (7psi) and hold for 15 minutes.
7. Evacuate to (½ Torr) 0.65 mBar and maintain for 1 hour.

The plant should now be sufficiently dehydrated and suitable for recharging.

Note: During installation keep all pipes capped to prevent dirt and moisture ingress. If polyolester oil becomes contaminated with moisture then it is advisable to change the oil and filter drier.

ALTERNATIVE REFRIGERANTS

There are now an increasing number of transitional refrigerants as well as the traditional ones and if any refrigerant other than R 22 is used care must be taken in all aspects of installation and charging.

This is especially important with regard to the type of compressor oil used, and care must be taken to ensure that the correct oil is used with the correct refrigerant.

IMPORTANT:- If an alternative refrigerant is used, then this must be with the approval of Airedale International Air Conditioning Ltd. Use of an alternative refrigerant without the approval of AIAC Ltd could invalidate the warranty.

Electrical Information

CONTROL PANEL

Standard Wiring Diagram

The condensing units are designed to operate in conjunction with other Airedale units, and are also suitable for matching to other air handling units. A wiring diagram is supplied with each unit and should be referred to when carrying out the installation.

Components

CUS 15 - 30D AND HCU 20 - 30D

The following MCB's are fitted as standard:

- 1 Single phase control circuit breakers (mains and control voltage).
- 2 Three phase compressor circuit breakers.

The following contactors/overloads are fitted:

- 1 CP1 and CP2 - Main compressor contactors.
- 2 Compressor thermal overload (CU 30D only).
- 3 CD1 - Condenser Fan Contactor.

The following relays are fitted, some are option dependent:

- 1 R1 - Delay Start Relay - Circuit No 1.
- 2 R2 - Delay Start Relay - Circuit No 2.
- 3 R3 - HP/LP Trip Relay - Circuit No 2
- 4 R4 - Relay - Circuit No 1.
- 5 R5 - Relay - Circuit No 2.
- 6 R6 - HP/LP Trip Relay - Circuit No 1

Other components are as follows, some are option dependent:

- 1 Compressor Sequence Switch
- 2 T1 - Delay Start Timer - Circuit No 1
- 3 T2 - Delay Start Timer - Circuit No 2
- 4 In-line pressure switches (HP 2 off, LP 2 off).
- 5 Electronic pressure operated condenser fan speed controller (One Off)

CUS 40 - 60D

The following MCB's are fitted as standard:-

- 1 Single phase control circuit breakers (mains and control voltage)
- 2 Three phase compressor circuit breakers

The following contactors/overloads are fitted:-

- 1 CP1 to CP4 - Main compressor contactors
- 2 Compressor thermal overloads
- 3 CD1 and CD2 - Condenser Fan Contactors

The following relays are fitted, some are option dependent:

- 1 R1 and R3 - Delay Start Relay - Dual Compressor - Circuit No 1
- 2 R4 and R6 - Delay Start Relay - Dual Compressor - Circuit No 2
- 3 R2 and R5 - HP/LP Trip Relays

Other components are as follows, some are option dependent:

- 1 Compressor Sequence Switch
- 2 T1 and T2 - Delay Start Timer - Dual Compressor - Circuit No 1
- 3 T4 and T5 - Delay Start Timer - Dual Compressor - Circuit No 2
- 4 In-line pressure switches (HP 2 off, LP 2 off).
- 5 Electronic pressure operated condenser fan speed controller (Two Off)

Electrical Information

ELECTRICAL DATA

CUS		15D	20D	25D	30D	40D	50D	60D
Unit Data								
Nominal Run Amps (1)	A	30.4	35.6	47.2	53.0	62.8	82.9	97.5
Maximum Start Amps	A	115.7	140.2	202.3	205.0	149.5	164.8	220.5
Control Circuit	V	24VAC						
Mains Supply	V	400/3/50						
Permanent Supply	V	230/1/50						
Rec Mains Fuse	A	50	50	80	80	100	100	125
Rec. Permanent Fuse(2)	A	4	4	4	4	4	4	4
Max Incoming) Mains	mm ²	25	25	35	35	50	50	95
Cable Size) Perm	mm ²	2.5	2.5	2.5	2.5	2.5	2.5	2.5
Compressor								
Motor Rating	kW	6.9	8.9	11.6	13.4	8.9	8.9/13.4	13.4
Nominal Run Amps (1)	A	12.7	15.2	19.8	22.5	15.2	15.2/22.5	22.5
Locked Rotor Amps	A	98	120.0	175.0	175.0	120.0	120.0/175.0	175.0
Oil Sump Heater Rating	W	50	50	50	75	50	50/75	75
Type of Start		Direct on Line						
Condenser Fan								
Motor Rating	kW	0.55	0.55	0.55	0.55	0.55	0.55	0.55
Full Load	A	2.50	2.50	2.50	2.50	2.50	2.50	2.50
Locked Rotor Amps	A	5.80	5.80	5.80	5.80	5.80	5.80	5.80

(1) Nominal Run Amps based on 5°C evaporating and a 35°C ambient.

(2) CUS40-60 units do not require a separate permanent fused supply.

HCU		20D	25D	30D
Unit Data				
Nominal Run Amps (1)	A	38	46	56
Maximum Start Amps	A	127.4	157	207
Control Circuit	V	24VAC		
Mains Supply	V	400/3/50		
Permanent Supply	V	230/1/50		
Rec Mains Fuse	A	50	80	80
Rec. Permanent Fuse	A	4	4	4
Max Incoming) Mains	mm ²	25	35	35
Cable Size) Perm	mm ²	2.5	2.5	2.5
Compressor				
Motor Rating	kW	13.3	16.7	13.4
Nominal Run Amps (1)	A	14.9	19.2	24.2
Locked Rotor Amps	A	105	130	175.0
Oil Sump Heater Rating	W	18-38	18-38	75
Type of Start		Direct on Line		
Condenser Fan				
Motor Rating	kW	0.55	0.55	0.55
Full Load	A	2.50	2.50	2.50
Locked Rotor Amps	A	5.80	5.80	5.80

(1) Nominal Run Amps based on 5°C evaporating and a 35°C ambient.

Field Connections

CUS 15-30 & HCU 20-30 UNITS	L1	○	→ Mains Incoming 400/3/50
	L2	○	
	L3	○	
	N	○	
	E	○	
	L4	○	→ L4-N1 Permanent Supply 230/1/50
	N1	○	
	500	○	→ 0V → 24VAC Customer's Control → 502-530 Stage Two Cool - Customer's Control → 502-535 Stage One Cool - Customer's Control → 531-500 Liquid Line Solenoid - Circuit 2 → 532-500 Liquid Line Solenoid - Circuit 1
	502	○	
	530	○	
	535	○	
	531	○	
	532	○	
	526	○	
527	○	→ 526-527 Common Volt Free Alarm N/O Contact	

CUS 40-60 UNITS	L1	○	→ Mains Incoming 400/3/50
	L2	○	
	L3	○	
	N	○	
	E	○	
	L4	○	→ L4-N1 Permanent Supply 230/1/50
	N1	○	
	500	○	→ 0V → 24VAC - Customer's Control → 502-506 Stage One Cool - Customer's Control → 502-513 Stage Two Cool - Customer's Control → 522-552 Stage Three Cool - Customer's Control → 523-555 Stage Four Cool - Customer's Control
	502	○	
	506	○	
	513	○	
	522	○	
	552	○	
	523	○	
	555	○	
	507	○	
	514	○	
	507	○	→ 507-500 Liquid Line Solenoid 1 - Circuit 1 → 514-500 Liquid Line Solenoid 2 - Circuit 2
	514	○	
522	○		
523	○		
526	○	→ 507-500 Liquid Line Solenoid 1 - Comp 1, Circuit 1 → 514-500 Liquid Line Solenoid 2 - Comp 1, Circuit 2 → 522-500 Liquid Line Solenoid 3 - Comp 2, Circuit 1 → 523-500 Liquid Line Solenoid 4 - Comp 2, Circuit 2	
527	○		
526	○	→ 526-527 Common Volt Free Alarm N/O Contact	
527	○		

Commissioning Procedure – Example

<h1 style="margin: 0;">CONDENSERS/CONDENSING UNITS - C/CUS/CUHS/HCU/CFCUS</h1>		<p style="margin: 0;">Airedale International Air Conditioning Ltd Leeds Road, Rawdon, Leeds LS19 6JY ENGLAND Tel: 0113 239 1000 Fax: 0113 250 7219</p>	
<p>TO BE COMPLETED IN CONJUNCTION WITH COMMISSIONING PROCEDURE RETURN WHITE COPY TO AIREDALE/RETAIN PINK COPY</p>			
Engineer:		Company:	
Model:		Serial No:	
		Date:	
		Site Ref:	
1 Pre Commissioning Checklist			
1.1 Unit Condition Satisfactory		Comment:	
1.2 Holding charge retained		Circ 1	Yes/No
1.3 Electrical connections tight			Yes/No
1.4 Voltage at mains supply		L1-L2	V
		L2-L3	V
		L3-L1	V
1.5 System pressure test:			
i Initial test pressure		Circ 1	Barg
		Circ 2	Barg
ii Final test pressure		Circ 1	Barg
		Circ 2	Barg
iii Test duration		Circ 1	Hrs
		Circ 2	Hrs
2 Commissioning Checklist			
2.1 Final system vacuum		Circ 1	mBar
		Circ 2	mBar
2.2 Vacuum hold time		Circ 1	Min
		Circ 2	Min
2.3 Refrigerant type			
2.4 Refrigerant charge		Circ 1	kg
		Circ 2	kg
2.5 Timer settings correct and operational (if fitted)			
Low pressure override - 3mins		Circ 1	Mins
		Circ 2	Mins
Defrost - 30 mins		Circ 1	Mins
		Circ 2	Mins
Anti cycle timer -10 mins		Circ 1	Mins
		Circ 2	Mins
2.6 Head pressure control set		Circ 1	Barg
		Circ 2	Barg
2.7 HP/LP switch cut outs:		Circ 1	Barg
		Circ 2	Barg
i LP cut out - 2.0 barg		LP Cut Out	Barg
		LP Cut Out	Barg
ii LP cut in - 3.0 barg		LP Cut In	Barg
		LP Cut In	Barg
iii HP cut out - 27.0 barg		HP Cut Out	Barg
		HP Cut Out	Barg
2.8 HGBP valve setting (if fitted)		Circ 1	Barg
		Circ 2	Barg
2.9 Superheat at compressor		Circ 1	°C
		Circ 2	°C
2.10 Added oil volume (if applicable)		Circ 1	Lt
		Circ 2	Lt
2.11 Operating conditions:			
i Suction pressure		Circ 1	Barg
		Circ 2	Barg
ii Discharge pressure		Circ 1	Barg
		Circ 2	Barg
2.12 Compressor Amps (CU & CFCU)		L1	Amps
		L2	Amps
		L3	Amps
2.13 Condenser Fan Amps		/ /	Amps
		/ /	Amps
3 Other comments			

IMPORTANT: THIS IS AN IMPORTANT WARRANTY DOCUMENT AND WARRANTY COULD BE INVALIDATED SHOULD AIREDALE NOT HOLD A COPY ON FILE.

QTYENG 10 - 08/98

Commissioning Procedure

HEAD PRESSURE CONTROLLER ADJUSTMENT

CUS 15 - 30D AND HCU 20 - 30D

Cut Off Mode

The voltage output to the fan is varied between 0-100% allowing head pressure control in ambients down to -20 °C. This is selected by turning the knob on the fan speed controller fully anti-clockwise. Cut off mode is standard operation for Airedale condensing units and factory set.

Minimum Speed Mode

The minimum voltage output to the fan can be varied between 45-95% of supply voltage by adjusting the knob within the minimum speed mode on the fan speed controller.

Head pressure setting adjustment is achieved by altering the slotted dead screw on the pressure transducer.

CUS 40 - 60D

The head pressure can be controlled by the fan speed operation in one of two possible modes:

The head pressure is controlled by a separate head pressure controller for each refrigeration circuit. The head pressure controllers are enclosed in a plastic box which contains all the necessary components including the pressure transducer. Connection to the respective refrigeration circuit is via a capillary of suitable length.

There are Two control knobs in the controller.

The upper knob is used to set the minimum speed for the fans. This can be adjusted to be between 50% and 90% of full speed. If the control is set to 0% then the minimum speed function is disabled and the fan will operate over the whole range of 0% to 100% dependent upon the head pressure. 0% is the standard setting for these controllers on Airedale condensing units.

The lower knob is used to adjust the proportional band of the controller. This should be left at the factory setting.

Adjustment of head pressure setpoint is by means of the slotted head adjuster on the pressure transducer head on the right-hand side of the controller.

Troubleshooting

GENERAL

FAULT	POSSIBLE CAUSE	REMEDY / ACTION
Compressor not operating.	No power to compressor	Check isolator, fuses, MCBs, contactor and control circuit wiring
	Low pressure switch operated (large or complete loss of refrigerant charge).	Recover refrigerant, repair, evacuate and recharge system.
	Compressor thermal protection device operated	Check if compressor overheated - possibly short of refrigerant
	Condenser fan thermal trip open circuit	Investigate and correct.
	Seized compressor, possibly due to lack of oil.	Replace compressor - investigate oil trapping and general installation.
	Defective compressor motor.	Check winding resistances - replace compressor. If burnt out follow burn out procedure using suction line burn-out drier.
Noisy Compressor.	Lack of oil.	Repair leaks if any, add oil if required but not too much - remember too much is as bad as too little. Investigate pipe system and trapping. Best method to pump down to see if oil can be encouraged back. If no oil still, drain compressor and measure in correct quantity.
	Expansion valve stuck in open position (abnormally cold suction line).	Ensure feeler bulb is tight on suction and superheat is correct (normally 5 °C to 6 °C.). Replace power assembly or valve as necessary.
	Worn or scored compressor bearing. (excessive knocking).	Replace compressor.
Head Pressure too high.	Condenser coil clogged or dirty.	Clean condenser.
	Air or other non-condensable gas in system.	Evacuate system and re-charge with new refrigerant.
	Overcharge of refrigerant.	Remove excess refrigerant from system by recovery system.

Troubleshooting

REFRIGERATION

FAULT	POSSIBLE CAUSE	REMEDY / ACTION
Head pressure too high.	Condenser coil blocked or dirty	Clean condenser coil
	Head pressure controller faulty.	Check fan speed controller - if faulty - replace.
	Fan not operating or operating inefficiently.	Check motor - if faulty - replace.
Head pressure too low.	Fan operating too fast in low ambient conditions.	Check fan speed controller adjustment - if faulty - replace.
Compressor short cycles or LP cut-out operated.	LP switch set too high.	Adjust/replace as appropriate.
	Lack of refrigerant (bubbles in sight glass only as indication).	Check for leaks – reclaim refrigerant, repair, evacuate and recharge system.
	Clogged filter drier (pressure / temperature drop across it).	Replace once the cause has been identified and rectified.
	Condenser fan running at full speed in winter (full airflow).	Check fan speed controller setting - if faulty - replace.
Suction Pressure too low.	Low evaporator airflow (not Airedale Unit).	Check fan motors, belts and drives.
	Flash gas (bubbles in sight glass) at expansion valve.	Investigate for refrigerant leaks, repair and re-charge system.
	Clogged filter drier (pressure / temperature drop across it).	Replace.
	Obstruction in liquid line solenoid valve.	Pump down, inspect, clean or replace.
	Obstruction in expansion valve.	Pump down, inspect, clean or replace.

Troubleshooting

REFRIGERATION

FAULT	POSSIBLE CAUSE	REMEDY / ACTION
Condenser fan not operating - power on.	Motor / fan assembly jammed	Isolate unit and check free rotation of motor / fan assembly. If faulty - replace.
	Fault at motor terminal box supply terminals	Isolate and check electrical connections are secure.
	Motor internal overheat protector tripped.	Carry out continuity check at terminals “TK” in motor terminal box. If tripped and motor hot - check bearings. If tripped and motor cold - replace motor.
	Power supply failure	Check power supply at circuit breaker.
	Wiring to motor	Check voltage at motor terminals.
	Faulty motor windings / capacitor	Motor humming would indicate fault in motor or capacitor.
	Minimum speed set too low.	Adjust head pressure controller to suit.
Faulty pressure sensor.	Faulty pressure sensor.	Check electrical connections are secure at controller and pressure sensor. Replace controller and sensor (as they are matched sets).
	Faulty Controller.	Link wires “line” and “load” to bypass controller. If motor runs full speed - replace unit.
Condenser fan runs too fast.	High ambient condition or excessive re-circulation of air around condenser coil.	Check installation against design.
	Minimum speed setting incorrect.	Adjust as necessary.
	Incorrect pressure setting.	Adjust sensor screw as necessary.
	Faulty Controller.	Replace controller and sensor (as they are matched sets).
Faulty pressure sensor.	Faulty pressure sensor.	Replace controller and sensor (as they are matched sets).
Condenser fans runs only slowly.	Incorrect pressure setting.	Adjust sensor screw as necessary.
	Faulty Controller.	Replace controller and sensor (as they are matched sets).
	Faulty Pressure sensor.	Replace controller and sensor (as they are matched sets).
	Motor wired incorrectly.	Check against wiring diagram - correct as required.
Motor / capacitor faulty.	Replace.	

Maintenance Requirements

SAFETY

WARNING : *Ensure that ALL power to the unit is switched OFF before carrying out any servicing or maintenance task.*

ACCESS

CUS 15 - 30D

Access to the compressors is via removable covers at the control panel end of the unit. The low covers allow access to the compressors whilst the upper doors allow access to the control panel.

Access is gained to the fan(s) from the top of the unit.

CUS 40 - 60D

Access to the compressors is via removable covers at the opposite end to the control panel. In both cases there are removable covers which can be lifted off or hinged back depending upon their location.

SERVICE CHECKS - THREE MONTHLY

At every service visit the following checks should be carried out:-

FAN AND MOTOR ASSEMBLY

- 1 Examine the fan and motor assemblies for lateral and end play in the bearings.
- 2 Examine the electrical gland plate to ensure that no water is entering the motor.
- 3 Examine the fan blades for damage and corrosion.

REFRIGERATION CIRCUITS

- 1 Check the suction and discharge pressures using a service gauge manifold and compare them with the commissioning sheet. If there is any significant variation, then the fault should be found and corrected. Refer to the troubleshooting section.
- 2 Check that the high and low pressure switches are cutting out the compressors at the correct settings.

High pressure switch cut-out	27.6 bar
Low pressure switch cut-out	0.5 bar
Low pressure switch cut-in	2.5 bar
Low pressure switch differential	2.0 bar

Ensure that both switches stop the compressor.
- 3 Ensure the fan head pressure controller is controlling the head pressure at the required setting as shown on the commissioning sheets.

The gauges can then removed from the system. Do not forget to replace the security caps on the schraeder valves.

CONDENSER COIL

Clean the condenser coil with a stiff bristled hand brush. If dirt has accumulated over a long period, or tends to be greasy or sticky, then it may be necessary to use a water hose or chemical pressure hose. Take care not to damage the fins and comb out if they have become damaged in any way.

IMPORTANT:- DO NOT USE STEAM FOR CLEANING CONDENSER COILS OTHERWISE DAMAGE OR DANGER MAY RESULT FROM EXCESSIVE INTERNAL PRESSURES.

Maintenance Requirements

CABINET

Wash down cabinet using a mild detergent. Treat any paint damage or rust as necessary.

ELECTRICAL

- 1 Check all electrical connections for signs of overheating or arcing.
- 2 Check all cables for signs of chafing or physical damage.

SERVICE CHECKS - YEARLY

As three-monthly plus the following:-

- 1 Check all electrical connections for tightness.
- 2 Check all refrigeration connections with leak detector.

Notes:



Head Office:

Airedale International Air Conditioning Ltd
Leeds Road
Rawdon
Leeds LS19 6JY
United Kingdom

Tel: +44 (0) 113 239 1000
Fax: +44 (0) 113 250 7219

e-mail: enquiries@airedale.com
website: www.airedale.com

A  **MODINE** Company