

Condensing Units

CU 1 – CU 4
3.3 – 13.0 kW



TECHNICAL MANUAL



FM00542

EMS52086

About Airedale Products & Customer Services

WARRANTY, COMMISSIONING & MAINTENANCE

As standard, Airedale guarantees all non consumable **parts only** for a period of **24 months**, variations tailored to suit product and application are also available, please contact Airedale for full terms and details.

To further protect your investment in Airedale products, we have introduced Airedale Service, who can provide full commissioning services, comprehensive maintenance packages and service cover 24 hours a day, 365 days a year (UK mainland). For a free quotation contact our Airedale Service or your local Sales Engineer.

CAUTION

Warranty cover is not a substitute for Maintenance. Warranty cover is conditional to maintenance being carried out in accordance with the recommendations provided during the warranty period. Failure to have the maintenance procedures carried out will invalidate the warranty and any liabilities by Airedale International Air Conditioning Ltd.

SPARES

A spares list for 1, 3 and 5 years will be supplied with every unit and is also available from our Spares department on request.

TRAINING

As well as our comprehensive range of products, Airedale offers a modular range of Refrigeration and Air Conditioning Training courses, for further information please contact our Training Co-ordinator.

CUSTOMER SERVICES

For further assistance, please e-mail: enquiries@airedale.com or telephone:

UK Sales Enquiries	+ 44 (0) 113 238 7789	uk.sales@airedale.com
International Enquiries	+ 44 (0) 113 239 1000	enquiries@airedale.com
Spares Hot Line	+ 44 (0) 113 238 7878	spares@airedale.com
Airedale Service	+ 44 (0) 113 239 1000	service@airedale.com
Technical Support	+ 44 (0) 113 239 1000	tech.support@airedale.com
Training Enquiries	+ 44 (0) 113 239 1000	marketing@airedale.com

For information, visit us at our Web Site: www.airedale.com

AIAC Ltd endeavours to ensure that the information in this document is correct and fairly stated, but none of the statements are to be relied upon as a statement or representation of fact. AIAC Ltd does not accept liability for any error or omission, or for any reliance placed on the information contained in this document.

The development of Airedale products and services is continuous and the information in this document may not be up to date. It is important to check the current position with AIAC Ltd at the address stated. This document is not part of a contract or licence unless expressly agreed.

No part of this document may be reproduced or transmitted in any form or by any means, electronic or mechanical, including photocopying, recording, or information storage and retrieval systems, for any purpose other than the purchaser's personal use, without the express written permission of AIAC Ltd.

© 2015 Airedale International Air Conditioning Limited. All rights reserved. Printed in the UK.

General Description

UNIT IDENTIFICATION

AIR COOLED CONDENSING UNIT & OUTDOOR HEAT PUMP RANGE	
CU	Condensing Unit Cooling Only
CUH	Outdoor Heat Pump
S	Scroll Compressor (Model sizes 2-4)
1-4	Model Size
HI	Head Pressure Control & Mains Isolator
Example	CUHS2

INTRODUCTION

This range of 8 air cooled condensing units and heat pumps covers the range of 3.3 to 13kW in cooling mode.

All condensing units are factory fitted with head pressure control and mains isolator as standard.

The range is custom designed for a small footprint, low noise level, slimline and aesthetically pleasing appearance and lend themselves to wall mounting applications. These units can be used with many Airedale products from the mini split Answer Cassette and Concept 2000 units, Comfort modular comfort products and close control products. They can also be utilised as heat rejection equipment for applications featuring other cooling units.

CE DIRECTIVE



Airedale certify that the equipment detailed in this manual conforms with the following EC Directives:

Electromagnetic Compatibility Directive (EMC)	89/336/EEC
Low Voltage Directive (LVD)	73/23/EEC
Machinery Directive (MD)	89/392/EEC in the version 98/37/EC
Pressure Equipment Directive (PED)	97/23/EC

To comply with these directives appropriate national & harmonised standards have been applied. These are listed on the Declaration of Conformity, supplied with each product.

Maximum and Minimum Operation Temperature (TS) and Pressure (PS)	
Operating Temperature (TS),	TS = Min -20°C to Max 120°C *
Maximum Operating Pressure (PS)	PS = High Side 26 Barg

*Based upon the maximum machine running temperatures.

CONSTRUCTION

Unit cabinets are manufactured from galvanised sheet steel coated with epoxy baked powder paint to provide a durable finish.

Standard unit colour is Light Grey (RAL 7035).

Access to the compressors is via removable panels at the end and side of the unit.

STANDARD FEATURES

CONDENSER

A large surface area coil, ideally positioned to optimise airflow and heat transfer and manufactured from refrigeration quality copper tubes with mechanically bonded aluminium fins.

FAN & MOTOR ASSEMBLY

Axial flow fan assembly with low noise sickle type blades and inlet ring.

The external rotor motor allows the use of a low power output, single phase, speed controllable motor to power the fan.

The motor has inbuilt thermal overload protection and the assembly is supplied complete with a finger guard for protection.

COMPRESSOR

CU/CUH 1 - 1.5

Fully hermetic reciprocating compressor fitted as standard with Internal thermal motor protection. Compressor(s) are mounted to the base via the use of vibration isolators.

CUS/CUHS 2 - 4

Hermetic scroll compressors fitted as standard with Internal thermal motor protection and Internal pressure relief valve. Compressor(s) are mounted to the base via the use of vibration isolators.

PRE CHARGE

All Condensing Units are supplied pre-charged with R407c for a pipe run of up to 7 metres. Refrigerant must be added for longer pipe runs (refer to **Technical Data** for further information).

General Description

REFRIGERATION

Cooling Only

Each unit features as standard:

- Liquid Line shut off valve
- Suction Line shut off valve
- High & Low pressure switches
- Filter drier (loose)
- Operating Charge

Heat Pump

Each unit features as standard:

- Liquid shut off valve
- Suction shut off valve
- High & Low pressure switches
- Filter drier biflow (loose)
- Reversing valve
- Defrost function
- Oil sump heater
- Suction line accumulator
- Check valve (TEV inbuilt)
- Externally equalised bi-directional thermostatic expansion valve

CONTROLS

A custom designed microprocessor system has been developed and is fitted to the units as standard so that an Airedale indoor unit can be matched to the Condensing unit, and communication is available via a simple 2-wire link.

As standard the microprocessor is programmed with compressor anticycle protection, to prevent short cycling and subsequent additional wear on the compressor, limiting the compressor starts to 6 per hour.

As an additional feature, communication between indoor and outdoor microprocessor units is carried by means of a low voltage 2 core screened cable.

A set of volt free contacts, to relay a unit trip, is provided as standard.

Alternatively, the condensing unit can be supplied with electro-mechanical controls – refer to **Optional Extras** for details.

ELECTRICAL

The unit control panel is fitted with the necessary contactors, sub-circuit protection and terminals to allow efficient and continuous unit operation.

All wiring is colour coded and numbered for identification and all units are wired to current local and European standards.

HEAD PRESSURE CONTROL

Head pressure is maintained by a factory fitted head pressure controller which varies the speed of the fan(s) to provide optimum control under varying ambient conditions.

MAINS ELECTRIC ISOLATOR

To ensure complete unit isolation of the electrical panel during adjustment and maintenance.

The factory-fitted isolating device is a door interlocking type, preventing the panel from being accessed when the unit is running.

OPTIONAL EXTRAS

Epoxy Coated Condenser Coils

In atmospheres where high corrosion is anticipated epoxy coated aluminium finned coils can be fitted.

Wall Mounting Brackets

To allow wall mounting a bracket and fixing kit can be supplied.

Defrost Drain Tray

A stainless steel drain tray can be provided to collect condensate when units are used in heat pump mode. Recommended for wall mounted installations.

Hot Gas Bypass

To achieve capacity control during low load conditions or to maintain suction pressure when used with fresh air systems, the hot gas bypass system will modulate the capacity down to 40% of full load. A stub is provided for site connection of the hot gas line to the local expansion device. The hot gas option is supplied as a loose field fit kit.

Electro-Mechanical Controls

The condensing unit can be supplied with electro-mechanical controls to operate via a cooling/heating signal from the indoor unit. This is suitable where the condensing unit is matched to a non-Airedale indoor unit.

Phase Rotation Protection

A phase sequence relay is available for units containing 3 phase scroll compressors, to prevent possible damage by running the compressor in the wrong direction.

Capacity Data - Cooling Only Unit

Cooling Duty	Mean Evaporating Temperature °C	Ambient									
		25°C		30°C		35°C		40°C		45°C	
		Output kW	Input kW	Output kW	Input kW	Output kW	Input kW	Output kW	Input kW	Output kW	Input kW
CU1	-5	2.62	0.90	2.45	1.04	2.30	1.19	2.13	1.33	1.96	1.47
	0	3.11	0.95	2.92	1.08	2.73	1.23	2.55	1.37	2.35	1.51
	5	3.70	0.98	3.50	1.12	3.30	1.26	3.10	1.41	2.90	1.55
	10	4.32	1.02	4.11	1.15	3.90	1.28	3.67	1.44	3.44	1.59
CU1.5	-5	3.57	1.27	3.35	1.47	3.14	1.68	2.91	1.87	2.68	2.08
	0	4.25	1.31	4.02	1.52	3.79	1.71	3.55	1.92	3.31	2.13
	5	5.05	1.38	4.79	1.58	4.51	1.78	4.24	1.99	3.97	2.19
	10	5.90	1.44	5.62	1.63	5.33	1.81	5.02	2.04	4.70	2.25
CUS2	-5	4.01	1.09	3.76	1.26	3.52	1.44	3.27	1.61	3.01	1.79
	0	4.77	1.13	4.51	1.31	4.25	1.47	3.98	1.65	3.71	1.83
	5	5.67	1.19	5.37	1.36	5.06	1.53	4.76	1.71	4.45	1.88
	10	6.62	1.24	6.30	1.40	5.98	1.56	5.63	1.75	5.27	1.93
CUS2.5S	-5	5.97	1.74	5.61	2.01	5.24	2.26	4.83	2.55	4.41	2.83
	0	7.12	1.82	6.73	2.08	6.34	2.34	5.90	2.63	5.46	2.91
	5	8.40	1.93	7.98	2.18	7.55	2.42	7.06	2.72	6.56	3.01
	10	9.80	2.03	9.32	2.27	8.84	2.51	8.26	2.80	7.68	3.08
CUS2.5T	-5	5.90	1.72	5.69	2.00	5.47	2.27	5.27	2.54	5.53	2.82
	0	7.18	1.83	6.81	2.08	6.43	2.34	6.07	2.59	5.66	2.90
	5	8.40	1.91	7.99	2.17	7.57	2.42	7.13	2.71	6.68	2.99
	10	9.70	2.02	9.25	2.27	8.79	2.51	8.31	2.79	7.82	3.07
CUS3	-5	6.99	2.13	6.62	2.44	6.26	2.75	5.91	3.07	5.50	3.44
	0	8.28	2.27	7.86	2.54	7.44	2.81	6.99	3.14	6.54	3.53
	5	9.69	2.38	9.20	2.69	8.72	2.96	8.22	3.30	7.67	3.63
	10	11.20	2.51	10.67	2.79	10.12	3.09	9.55	3.42	8.99	3.74
CUS3.5	-5	8.66	2.48	8.19	2.79	7.71	3.10	7.23	3.42	6.75	3.73
	0	10.38	2.60	9.82	2.91	9.25	3.21	8.72	3.54	8.18	3.86
	5	12.35	2.77	11.56	3.05	10.76	3.33	10.24	3.66	9.72	3.98
	10	14.18	2.93	13.29	3.20	12.39	3.46	11.89	3.79	11.39	4.12
CUS4	-5	10.56	2.50	9.85	2.98	9.18	3.46	8.54	3.95	8.54	3.95
	0	12.44	2.63	11.74	3.11	11.05	3.59	10.32	4.07	9.78	4.61
	5	14.54	2.86	13.80	3.33	13.05	3.79	12.37	4.27	11.75	4.80
	10	16.95	3.11	16.17	3.56	15.38	4.00	14.51	4.45	13.62	5.00

- 1 Output kW refers to the compressor duty.
- 2 Input kW refers to the compressor input power only.
- 3 Cooling data for a cooling only unit.

Capacity Data - Heat Pump Unit

Cooling Duty	Mean Evaporating Temperature °C	Ambient									
		25°C		30°C		35°C		40°C		45°C	
		Output kW	Input kW	Output kW	Input kW	Output kW	Input kW	Output kW	Input kW	Output kW	Input kW
CUH1	-5	2.62	0.90	2.45	1.04	2.30	1.19	2.13	1.33	1.96	1.47
	0	3.11	0.95	2.92	1.08	2.73	1.23	2.55	1.37	2.35	1.51
	5	3.70	0.98	3.50	1.12	3.30	1.26	3.10	1.41	2.90	1.55
	10	4.32	1.02	4.11	1.15	3.90	1.28	3.67	1.44	3.44	1.59
CUH1.5	-5	3.57	1.27	3.35	1.47	3.14	1.68	2.91	1.87	2.68	2.08
	0	4.25	1.31	4.02	1.52	3.79	1.71	3.55	1.92	3.31	2.13
	5	5.05	1.38	4.79	1.58	4.51	1.78	4.24	1.99	3.97	2.19
	10	5.90	1.44	5.62	1.63	5.33	1.81	5.02	2.04	4.70	2.25
CUHS2	-5	3.85	1.05	3.61	1.21	3.38	1.38	3.14	1.55	2.89	1.72
	0	4.58	1.08	4.33	1.26	4.08	1.41	3.82	1.58	3.56	1.76
	5	5.44	1.14	5.16	1.31	4.86	1.47	4.57	1.64	4.27	1.80
	10	6.36	1.19	6.05	1.34	5.74	1.50	5.40	1.68	5.06	1.85
CUHS2.5S	-5	5.73	1.67	5.39	1.93	5.03	2.17	4.64	2.45	4.23	2.72
	0	6.84	1.75	6.46	2.00	6.09	2.25	5.66	2.52	5.24	2.79
	5	8.06	1.85	7.66	2.09	7.25	2.32	6.78	2.61	6.30	2.89
	10	9.41	1.95	8.95	2.18	8.49	2.41	7.93	2.69	7.37	2.96
CUHS2.5T	-5	5.66	1.65	5.46	1.92	5.25	2.18	5.06	2.44	5.31	2.71
	0	6.89	1.76	6.54	2.00	6.17	2.25	5.83	2.49	5.43	2.78
	5	8.06	1.83	7.67	2.08	7.27	2.32	6.84	2.60	6.41	2.87
	10	9.31	1.94	8.88	2.18	8.44	2.41	7.98	2.68	7.51	2.95
CUHS3	-5	6.71	2.04	6.36	2.34	6.01	2.64	5.67	2.95	5.28	3.30
	0	7.95	2.18	7.55	2.44	7.14	2.70	6.71	3.01	6.28	3.39
	5	9.30	2.28	8.83	2.58	8.37	2.84	7.89	3.17	7.36	3.48
	10	10.75	2.41	10.24	2.68	9.72	2.97	9.17	3.28	8.63	3.59
CUHS3.5	-5	8.31	2.38	7.86	2.68	7.40	2.98	6.94	3.28	6.48	3.58
	0	9.96	2.50	9.42	2.79	8.88	3.08	8.37	3.39	7.85	3.71
	5	11.86	2.66	11.09	2.93	10.33	3.20	9.83	3.51	9.33	3.82
	10	13.61	2.81	12.75	3.07	11.89	3.32	11.41	3.64	10.93	3.96
CUHS4	-5	10.14	2.40	9.46	2.86	8.81	3.32	8.20	3.79	8.20	3.79
	0	11.94	2.52	11.27	2.99	10.61	3.45	9.91	3.91	9.39	4.43
	5	13.96	2.75	13.25	3.20	12.53	3.64	11.88	4.10	11.28	4.61
	10	16.27	2.99	15.52	3.42	14.76	3.84	13.93	4.27	13.08	4.80

- 1 Output kW refers to the compressor duty.
- 2 Input kW refers to the compressor input power only.
- 3 Cooling data for a cooling only unit.

Heating Duty	Outdoor Air On °C %RH		Mean Condensing Temperature					
			30°C	35°C	40°C	45°C	50°C	55°C
			Output kW	Output kW	Output kW	Output kW	Output kW	Output kW
CUH1	5	85	3.81	3.76	3.70	3.72	3.70	3.51
	7	85	4.02	3.95	3.90	3.91	3.75	3.63
	10	80	4.29	4.22	4.16	4.16	4.15	4.11
CUH1.5	5	85	4.70	4.63	4.62	4.59	4.57	4.55
	7	85	4.98	4.90	4.87	4.84	4.80	4.78
	10	80	5.32	5.23	5.19	5.14	5.31	5.41
CUHS2	5	85	5.44	5.37	5.29	5.32	5.29	5.01
	7	85	5.74	5.65	5.57	5.59	5.36	5.19
	10	80	6.13	6.03	5.94	5.94	5.93	5.88
CUHS2.5S	5	85	8.14	8.02	7.99	7.95	7.91	7.87
	7	85	8.63	8.49	8.43	8.38	8.31	8.27
	10	80	9.19	9.04	8.99	8.93	8.87	8.72
CUHS2.5T	5	85	8.14	8.02	7.99	7.95	7.91	7.87
	7	85	8.63	8.49	8.43	8.38	8.31	8.27
	10	80	9.19	9.04	8.99	8.93	8.87	8.77
CUHS3	5	85	9.30	9.25	9.20	9.17	9.12	9.09
	7	85	9.83	9.79	9.77	9.77	9.76	9.73
	10	80	10.59	10.46	10.32	10.26	10.20	10.08
CUHS3.5	5	85	11.92	11.71	11.62	11.51	11.40	11.32
	7	85	12.61	12.36	12.27	12.15	12.00	11.89
	10	80	13.51	13.23	13.12	12.95	12.78	12.59
CUHS4	5	85	13.57	13.51	13.48	13.43	13.38	13.36
	7	85	14.34	14.25	14.21	14.14	14.06	14.01
	10	80	15.42	15.19	15.08	15.02	14.89	14.79

- 1 Output kW refers to the compressor duty.
- 2 Indoor ambient at 20°C.

Operating Data

OPERATING LIMITS

Cooling Only

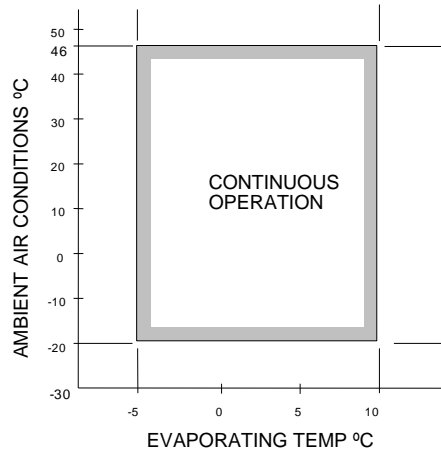

Heat Pump

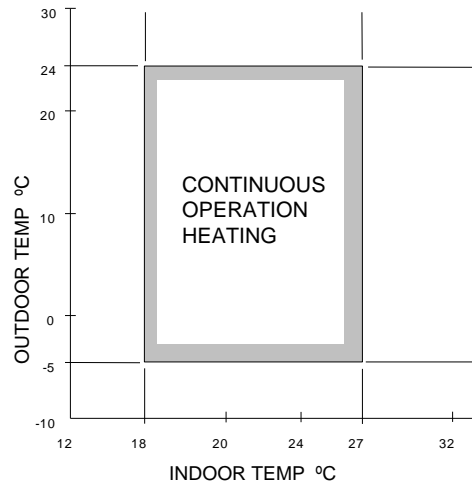
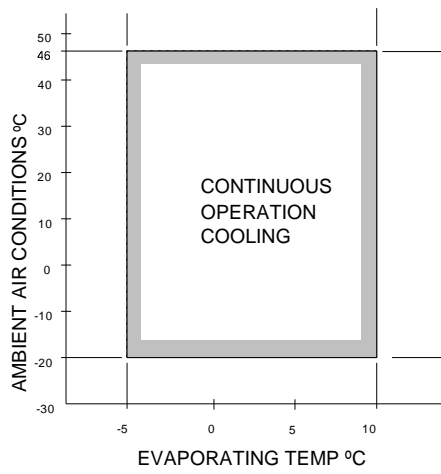

Dimensions

DIMENSIONS / POSITIONING / WEIGHTS

CU. / CUH. 1 - 4

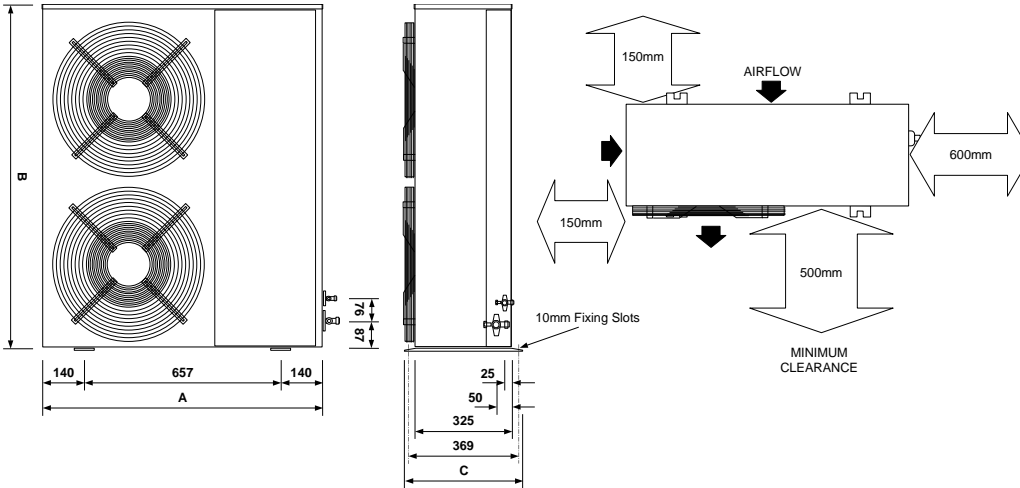

Models	Dimensions	A	B	C	Operating Weights
CU1	mm	937	843	395	51.0 kg
CU1.5	mm	937	843	395	59.0 kg
CUS2	mm	937	843	395	60.2 kg
CUS2.5S & T	mm	937	843	395	75.7 kg
CUS3	mm	937	1130	395	88.1 kg
CUS3.5	mm	937	1130	395	101.6 kg
CUS4	mm	937	1130	395	104.1 kg
CUH1	mm	937	843	395	53.0 kg
CUH1.5	mm	937	843	395	61.0 kg
CUHS2	mm	937	843	395	61.8 kg
CUHS2.5S & T	mm	937	843	395	78.4 kg
CUHS3	mm	937	1130	395	83.6 kg
CUHS3.5	mm	937	1130	395	106.0 kg
CUHS4	mm	937	1130	395	109.4 kg

- 1 Incoming Electrical Service holes (3 x 20mm Ø) to rear of unit.
- 2 Models CUS3 has 1 vertically aligned condenser fan.

Optional Wall Mounting Bracket

Self-assembly, Multi-fit Construction

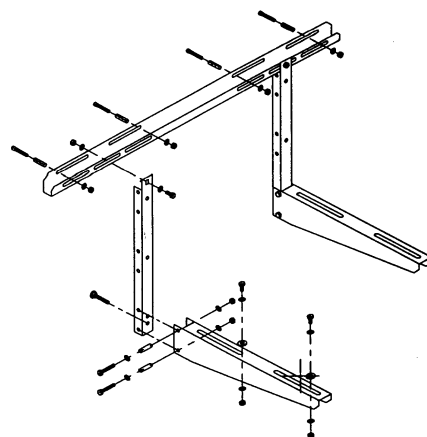

Technical Data

CU/CUH		1	1.5	S2	S2.5S	S2.5T	S3	S3.5	S4
Nominal Capacity - Cooling (1)	kW	3.3	4.5	5.1	7.6	7.6	8.7	10.8	13.1
Nominal Input (1)	kW	1.3	1.8	1.5	2.4	2.4	3.0	3.3	3.8
Capacity Steps	%	0-100	0-100	0-100	0-100	0-100	0-100	0-100	0-100
Construction									
Material		Galvanised Steel							
Colour		Light Grey (RAL 7035)							
Condenser									
Type		Air Cooled							
Quantity		1	1	1	1	1	1	1	1
Face Area	m ²	0.76	0.76	0.76	0.76	0.76	0.89	0.89	0.89
Nominal Airflow	m ³ /s	0.80	0.80	0.80	0.80	0.80	0.80	1.45	1.80
Coil Volume	(2) l	2.03	2.03	2.03	4.33	4.33	5.12	5.12	5.12
Discharge		Horizontal							
Fans									
Type		Axial							
Quantity		1	1	1	1	1	2	2	2
Diameter	mm	450	450	450	450	450	450	450	450
Maximum Speed	rpm	840	840	840	840	840	840	840	840
Compressor									
Type		Reciprocating				Scroll			
Quantity		1	1	1	1	1	1	1	1
Oil Charge Volume	L	0.6	1.2	1.0	1.1	1.1	1.1	1.9	1.6
Refrigeration									
Number of Circuits		1	1	1	1	1	1	1	1
Refrigerant Type		R407C							
Refrigerant Charge	kg	0.85	1.00	0.60	1.30	1.30	1.50	1.50	1.50
Refrigeration Control		Thermostatic Expansion Valve (CUH Only)							
Dimensions/Weights CU Units									
Height	mm	843	843	843	843	843	1130	1130	1130
Width	mm	937	937	937	937	937	937	937	937
Depth	mm	395	395	395	395	395	395	395	395
Machine Weight (nom)	kg	50.2	58.0	57.2	73.5	73.5	85.0	98.6	101.0
Operating Weight (nom)	kg	51.0	59.0	60.2	75.7	75.7	88.1	101.6	104.1
Dimensions/Weights CUH Units									
Height	mm	843	843	843	843	843	1130	1130	1130
Width	mm	937	937	937	937	937	937	937	937
Depth	mm	395	395	395	395	395	395	395	395
Machine Weight (nom)	kg	52.2	60.0	58.6	75.4	75.4	80.4	103.0	103.4
Operating Weight (nom)	kg	53.0	61.0	61.8	78.4	78.4	83.6	106.0	109.4
Connections									
Liquid Line	(3) in	1/4	1/4	1/4	3/8	3/8	3/8	3/8	1/2
Suction Line	(3) in	1/2	1/2	5/8	3/4	3/4	3/4	3/4	3/4
Hot Gas Stub	in	1/2	1/2	1/2	1/2	1/2	1/2	1/2	1/2

(1) Nominal Capacity based on 5°C mean evaporating temperature and a 35°C ambient.

(2) Figures for guidance.

(3) Flare connections on service valves.

Electrical Data

CU/CUH			1	1.5	S2	S2.5S	S2.5T	S3.0	S3.5	S4.0
Unit Data										
Nominal Run Amps	(1)	A	6.0	9.7	10.3	14.3	6.4	7.1	8.8	9.5
Maximum Start Amps		A	35.0	59.0	49.6	78.6	39.1	46.6	59.2	67.0
Control Circuit		VAC	230	230	230	230	230	230	230	230
Mains Supply		V	230/1/50				400/3/50			
Rec. Mains Fuse		A	16	16	16	20	16	16	16	20
Max Incoming Mains		mm ²	6	6	6	6	6	6	6	6
Compressor										
Motor Rating		kW	1.1	1.7	1.7	2.5	2.5	2.9	3.7	4.0
Nominal Run Amps	(1)	A	5.5	9.4	9.6	13.6	5.7	6.4	7.5	8.2
Locked Rotor Amps		A	37.5	61.0	47.0	76.0	36.5	44.0	54.0	61.8
Crankcase Heater Rating	(2)	W	24	24	40	40	40	40	65	65
Type of Start	Direct on Line									
Condenser Fan										
Motor Rating		kW	0.15	0.15	0.15	0.15	0.15	0.15	0.15	0.15
Full Load Amps		A	0.65	0.65	0.65	0.65	0.65	0.65	0.65	0.65
Locked Rotor Amps		A	2.60	2.60	2.60	2.60	2.60	2.60	2.60	2.60

(1) Nominal data based on 5°C evaporating temperature and a 35°C ambient.

(2) Heat Pump units only.

Sound Data

CU/CUH	Sound Measurement	dBA	Frequency (Hz)						
			125	250	500	1000	2000	4000	
CU/CUH 1 - 1.5	Power	dBA	64	67	67	62	59	53	46
	Pressure	@ 1 m	53	40	47	49	48	43	36
	Pressure	@ 10 m	33	20	27	29	28	23	16
CUS/CUHS 2 - 3	Power	dBA	73	79	73	70	66	60	55
	Pressure	@ 1 m	62	71	63	59	58	52	47
	Pressure	@ 10 m	42	51	43	39	38	32	27
CUS/CUHS 3.5 - 4	Power	dBA	73	79	75	72	66	64	57
	Pressure	@ 1 m	65	71	67	64	58	56	49
	Pressure	@ 10 m	45	51	47	44	38	36	29

1 Above noise levels are with the condenser fan running at full speed. Under normal operating conditions (ambients up to 35°C) noise levels will be reduced by 3 - 4 dB.

Field Connections

MICROPROCESSOR CONTROLLED (AD05)

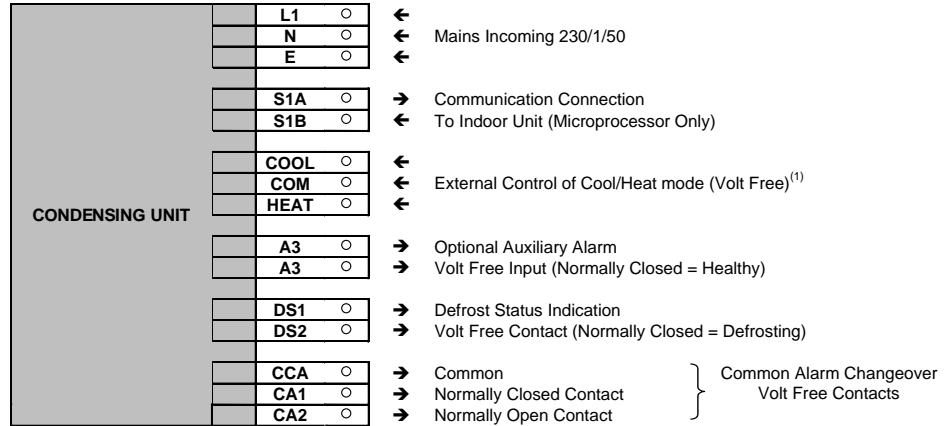

SYSTEM FIELD CONNECTIONS FOR AD05 CONTROLLED UNITS

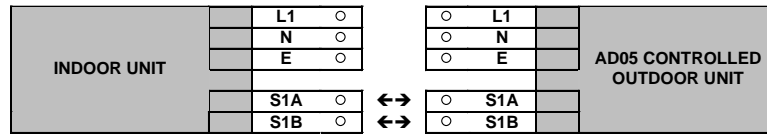

(1) The microprocessor (AD05) controlled condensing unit may be matched to non Airedale indoor air handling units.

A contact can be closed across either the Cool and Common or Heat and Common terminals. Ensure that the cooling and heating cannot be initialised simultaneously.

ELECTRO-MECHANICALLY CONTROLLED UNITS

Cooling Only Units

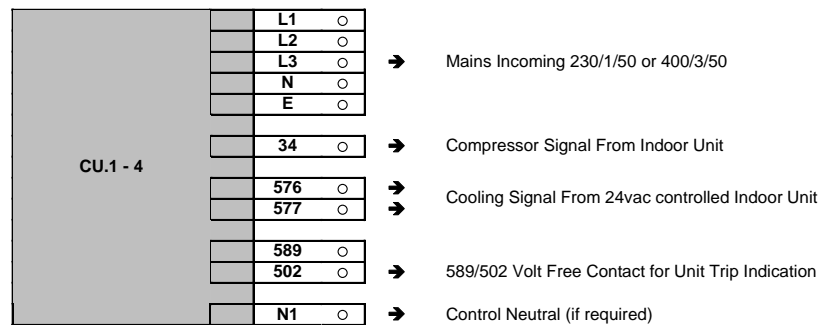

Heat Pump Units

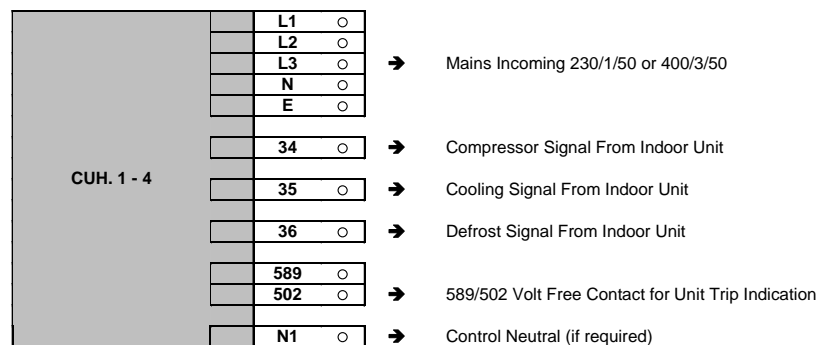

pLAN Terminations

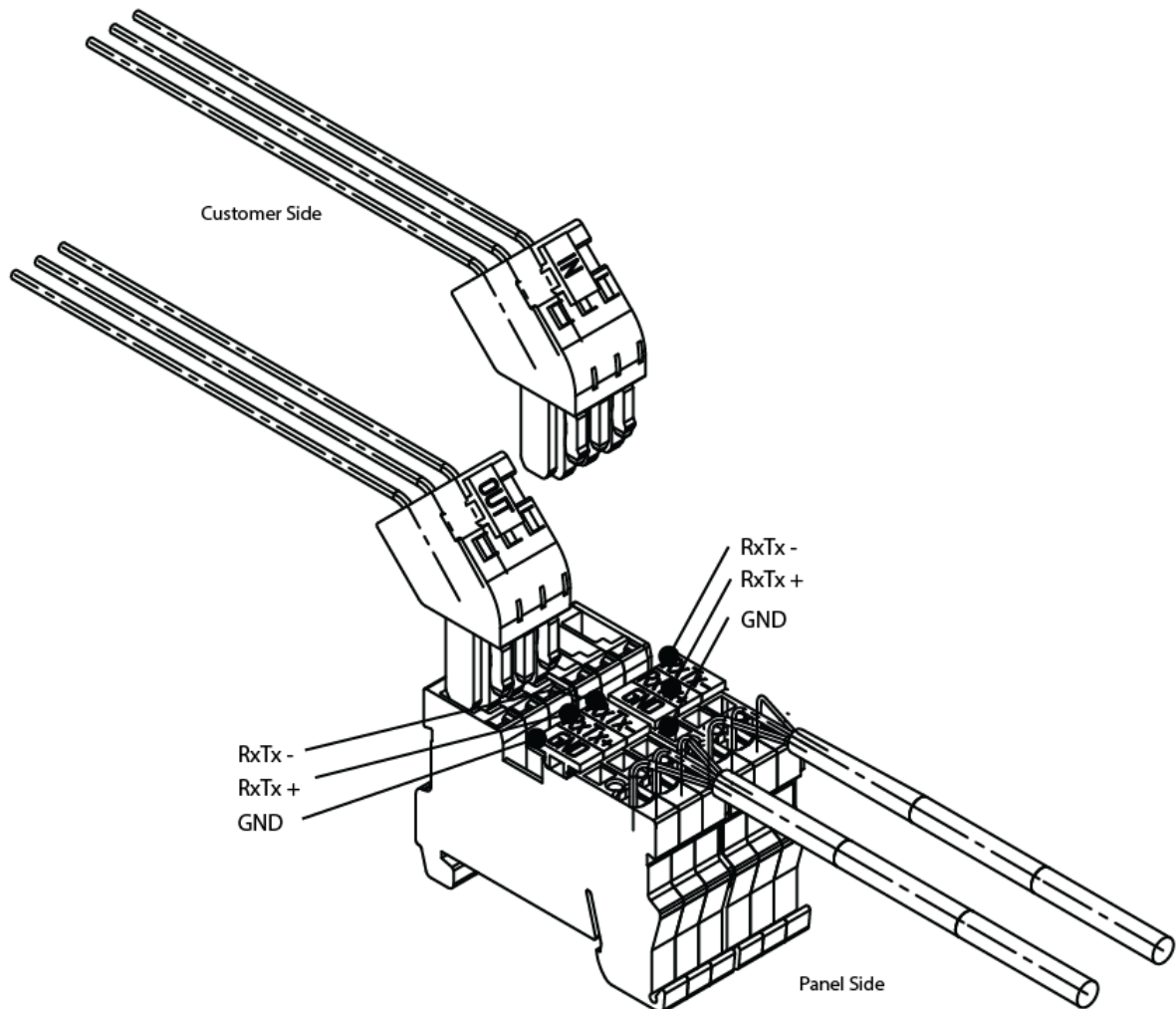

IMPORTANT: The plugged termination ensures that the connections are made simultaneously. Failure to attach the cables this way may cause damage to the controller.



Head Office:

Airedale International Air Conditioning Ltd
Leeds Road
Rawdon
Leeds LS19 6JY
United Kingdom

Tel: +44 (0) 113 239 1000
Fax: +44 (0) 113 250 7219

e-mail: info@airedale.com
website: www.airedale.com



PART NO:	ISSUE	DATE
6259618 TM E	A	01/09/09
	B	01/01/03
	C	01/03/03
	V1.3.0	02_2013
	V1.5.0	10/2014
	V1.6.0	10/2015